

583713/583814 MESH BACK CHAIR

OPERATING INSTRUCTIONS



FEATURES

• SEAT HEIGHT ADJUSTMENT

To raise seat remove pressure from seat and lift lever (1). To lower seat height sit on chair and lift lever (1).

NOTE: It is normal for chair to slightly lower under body weight.

• LOCKING TILT ADJUSTMENT

For individual comfort, this chair has been equipped with an adjustment that will allow the user to change the tension of the tilting feature. Turn knob (2) clockwise to increase tension and counter-clockwise to decrease or ease the tension. To lock return chair to the upright position and push lever (1) in. To unlock pull lever (1) out.

NOTE: Be careful not to loosen back tilt adjustment knob completely.

• ARM HEIGHT ADJUSTMENT

To adjust arm height, lift lever (3) adjust arm to desired height, release lever (3) to lock arm into position.

WARNING

1. Use this product only one person at a time.
2. Do not use this chair unless all bolts screws and knobs are securely tightened.
3. Check that all bolts screws and knobs are tight every three months or as needed.
4. Do not overturn back tilt knob when decreasing tension.
5. Dispose of packing material properly. Do not use plastic cover as head covering. It may cause suffocation.
6. Do not use chair as a stepladder.
7. Use this chair for its intended purpose only.
8. Use mild detergent only for cleaning.

LIMITED WARRANTY

Office Star chairs are warranted from the date of purchase against failure due to material and workmanship as follows:

- 5 Years on all non-moving metal parts.
- 2 Years on component parts including Control mechanisms, pneumatic cylinders, wood, plastic parts, base and casters.
- 1 Year on upholstery fabric and foam against wear and deterioration.
- We cannot warrant leather against routine scratching and scuffing, as all leather is subject to minor blemishes in normal use.

To make a warranty claim, contact Parts Department. Provide model number, proof of purchase, description of the problem and obtain return authorization. At its option Office Star Products will:

- (a) Supply compatible components of current manufacture.
- (b) Repair the customer's component. The customer must prepay freight on any components returned to the factory. Return freight on components still in warranty will be paid by Office Star Products.

**All warranties are limited to the original purchaser for normal Residential usage by persons weighing 200 lbs. or less. This warranty will not cover labor, freight or damage from misuse, abuse, negligence, alteration, accident, vandalism, rusting, acts of nature or any other event beyond the control of Office Star Products. The warranty does not cover cosmetic damage that may result from normal use. Liability for incidental or consequential damages is excluded. The user assumes all risk of injury resulting from use of this product. This warranty gives you specific legal rights, and you may also have other rights which vary from state to state.*

Our quality standards are among the highest in the industry. Sometimes, no matter how hard we try, there are times when parts are damaged or missing. Our Parts Department will do everything possible to promptly remedy the problem. Contact us via e-mail parts@officestar.net, by Fax 1-909-930-5629, or toll free parts number 1-800-950-7262, Monday through Friday 8:00 a.m. - 5:00 p.m. Pacific Time.

583713/583814 MESH BACK CHAIR

ASSEMBLY INSTRUCTIONS

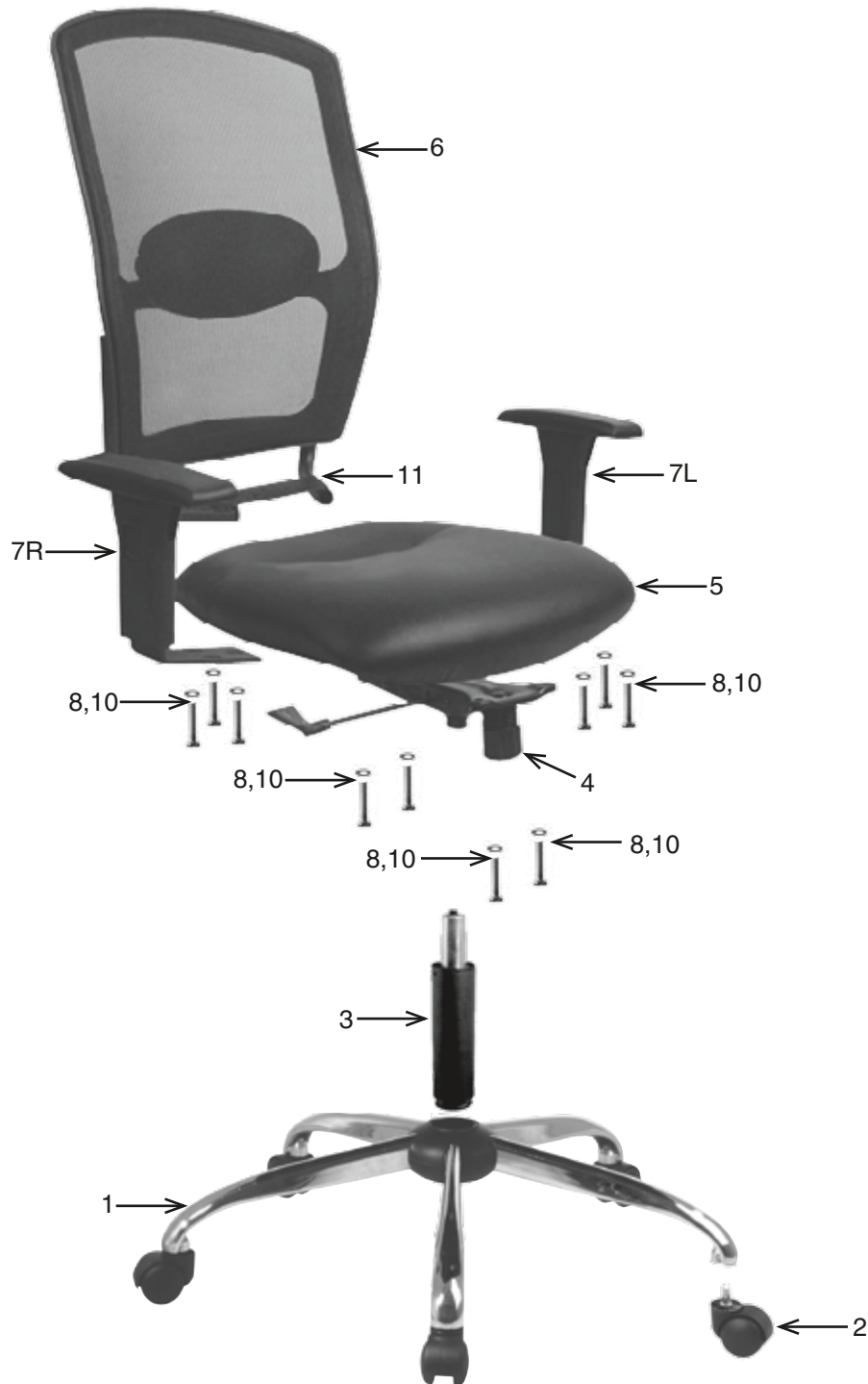

DETAIL A

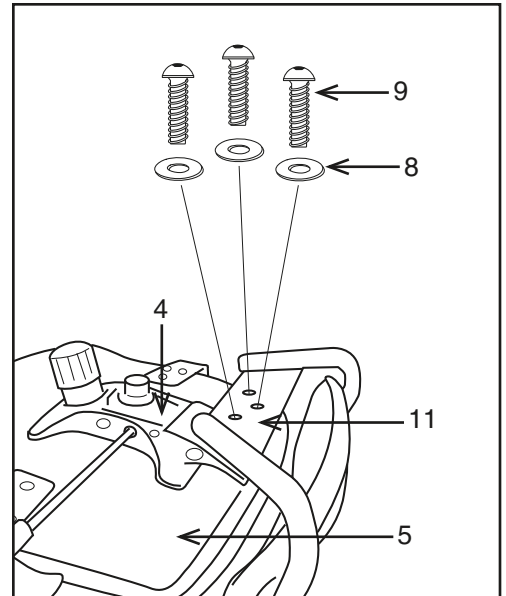

PART	QTY
1. Base	1
2. Casters	5
3. Pneumatic Cylinder	1
4. Mechanism	1
5. Seat Cushion	1
6. Back Assembly	1
7. Arms (7L & 7R)	2
8. Flat Washer	13
9. Short Screws	3
10. Long Screws	10
11. Back Support (Pre-Installed)	1
12. Allen Wrench (Not Shown)	1

Remove all parts from carton, separate by part numbers indicated on parts list, and verify part quantities.

STEP 1 Insert five Casters (2) into Base (1), push hard until you feel or hear the Caster (2) snap into place.

Insert Pneumatic Cylinder (3) into Base (1).

STEP 2 Attach Mechanism (4) to Seat Cushion (5) with the arrow pointing towards the front of the chair, using four Flat Washers (8), and Four Long Screws (10). **TIGHTEN ALL SCREWS COMPLETELY USING ALLEN WRENCH (12).**

STEP 3 Attach Back Support (11) to Mechanism (4) using three Flat Washers (8), and three Short Screws (9), **FULLY TIGHTEN ALL SCREWS USING ALLEN WRENCH (12).**

STEP 4 Align the holes in the Arms (7L & 7R) with the holes in the Seat Cushion (5), Attach Arms (7L & 7R) to Seat Cushion (5) using three Flat Washers (8) and three Long Screws (10) for each arm. **FULLY TIGHTEN ALL SCREWS USING ALLEN WRENCH (12).**

STEP 5 Place the assembled seat on top of Pneumatic Cylinder (3) and apply downward pressure.

ATTENTION: MAKE SURE ALL SCREWS ARE FULLY TIGHTENED BEFORE USING CHAIR.