

CT42R3 (MAHOGANY), CT42R7 (CHERRY) CONFERENCE TABLE OPERATING INSTRUCTIONS



WARNING

1. Do not use this product unless all screws and bolts are securely tightened.
2. Check that all screws and bolts are tight every three months or as needed.
3. Dispose of packing material properly. Do not use plastic cover as head covering. It may cause suffocation.
4. Do not use this product as a stepladder.
5. Use this product for its intended purpose only.

PROLINE II CONFERENCE TABLE LIMITED WARRANTY

ProLine II conference tables are warranted from the date of purchase against failure due to material and workmanship as follows:

- 5 years structural integrity
- 3 years on wood finishes

Grain, color and finishes

Variation of grain and color are natural, inherent characteristics of wood, a living material. This variation is part of the beauty of real wood and anticipated in wood veneer furnishings. Therefore, ProLine II Furniture is not warranted to match in grain or color or texture. It is a natural phenomenon for wood grain to change in color as it ages, and wood finishes are not warranted for color-fastness.

Warranty Exclusions

This warranty will not cover labor, freight, or damage from misuse, abuse, negligence, alteration, assembly, installation, attachments, accident, vandalism, acts of nature or any other event beyond the control of Office Star Products. The warranty does not cover cosmetic damage that may result from normal use. Liability for incidental or consequential damage is excluded. The user assumes all risk of injury resulting from use of this product.

This warranty applies only to products purchased through authorized Office Star Products ProLine II dealers and products sold within the United States of America and the Commonwealth of Canada. This warranty does not apply to products used for rental purposes. This warranty gives you specific legal rights, and you may also have other rights which vary from state to state.



CT42R3 (MAHOGANY), CT42R7 (CHERRY) CONFERENCE TABLE ASSEMBLY INSTRUCTIONS

IMPORTANT NOTE:

1. Use hand tools only for assembly as power tools may cause damage
2. Carefully remove any staples used for packaging.

PART	QTY
1. Top Panel	1
2. Large Leg Frame	1
3. Small Leg Frame	2
4. Cam Lock	14
5. Cam Lock Stud	14
6. Wooden Dowel	4
7. Plastic Cap	14

Phillips Screwdriver also needed for assembly (not provided)

STEP 1

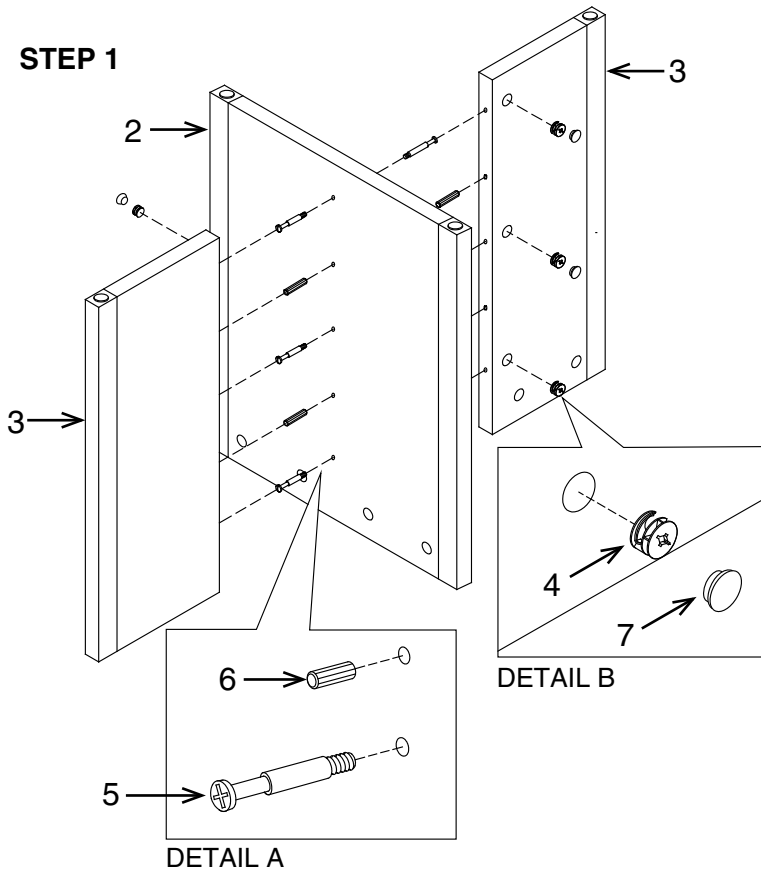

STEP 2

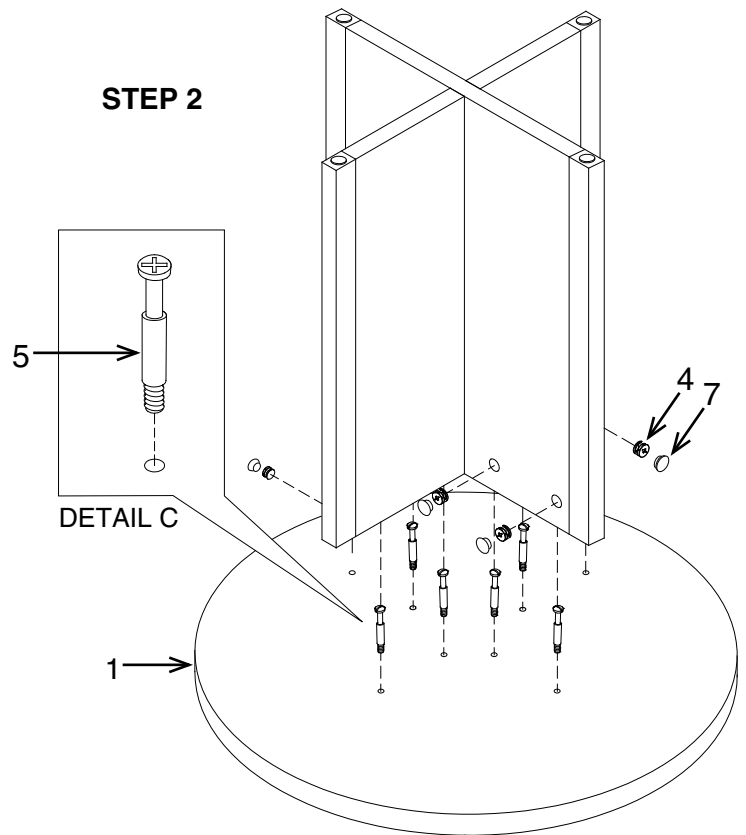

Remove all parts from carton, separate by part numbers indicated on parts list, and verify part quantities.

STEP 1 Insert two Wooden Dowels (6) into each side of Large Leg Frame (2), screw in three Cam Lock Studs (5) into each side of Large Leg Frame (2) **AS SHOWN IN DETAIL A**, align Small Leg Frames (3) with Large Leg Frame (2) and attach, secure using six Cam Locks (4) and **FULLY TIGHTEN CAM LOCKS (4) USING PHILLIPS SCREWDRIVER (not provided), AS SHOWN IN DETAIL B.**

STEP 2 Place Top Panel (1) face down on a soft surface, screw in eight Cam Lock Studs (5) into bottom of Top Panel (1), **FULLY TIGHTEN CAM LOCK STUDS (5) USING PHILLIPS SCREWDRIVER (not provided).** Align assembled leg frames to attached Cam Lock Studs (5) of Top Panel (1) and secure using eight Cam Locks (4), **FULLY TIGHTEN CAM LOCKS (4) USING PHILLIPS SCREWDRIVER (not provided).** Cover holes in table using fourteen Plastic Caps (7).

ATTENTION: MAKE SURE ALL CAM LOCKS ARE FULLY TIGHTENED BEFORE USING TABLE.